

Case Unit type TBC series

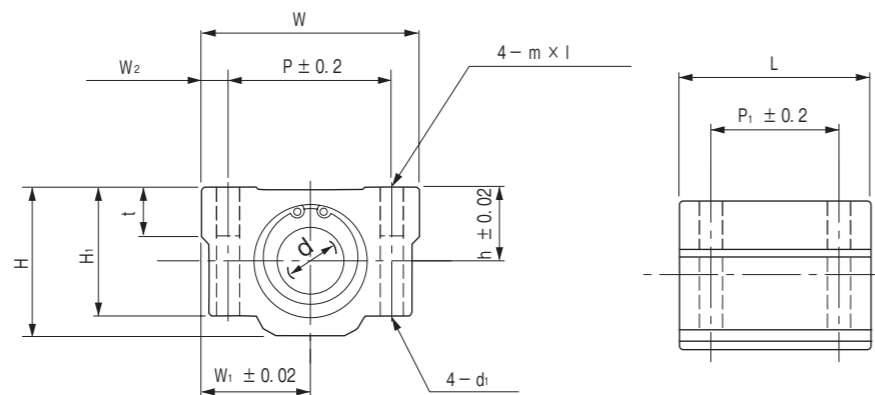

Shaft Diameter (mm)	Code Name	Major Dimensions (mm)													Basic Load Rating	
		d	W	H	L	h	W ₁	H ₁	W ₂	t	P	P ₁	m×l	d ₁	C (N)	C ₀ (N)
6	TBC-6UU	6	30	18	25	9	15	15	5	6	20	15	M 4×8	3.4	205	264
8	TBC-8UU	8	34	22	30	11	17	18	5	7	24	18	M 4×8	3.4	264	401
10	TBC-10UU	10	40	26	35	13	20	21	6	8	28	21	M 5×10	4.3	372	548
12	TBC-12UU	12	42	29	36	15	21	25	5.75	8	30.5	26	M 5×10	4.3	411	597
13	TBC-13UU	13	44	30	39	15	22	26	5.5	10	33	26	M 5×10	4.3	509	774
16	TBC-16UU	16	50	38.5	44	19	25	32.5	7	12	36	34	M 5×10	4.3	774	1,176
20	TBC-20UU	20	54	42	50	21	27	36	7	13	40	40	M 6×12	5.2	862	1,372
25	TBC-25UU	25	76	51.5	67	26	38	42	11	15	54	50	M 8×18	7	980	1,568
30	TBC-30UU	30	78	59.5	72	30	39	49	10	18	58	58	M 8×18	7	1,568	2,744
35	TBC-35UU	35	90	68	80	34	45	54	10	20	70	60	M 8×18	7	1,666	3,136
40	TBC-40UU	40	102	78	90	40	51	62	11	23	80	60	M10×25	8.7	2,156	4,018

● Code Name

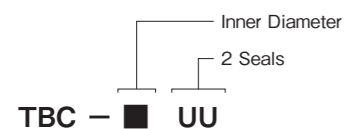

Case Unit Double type TBCW series

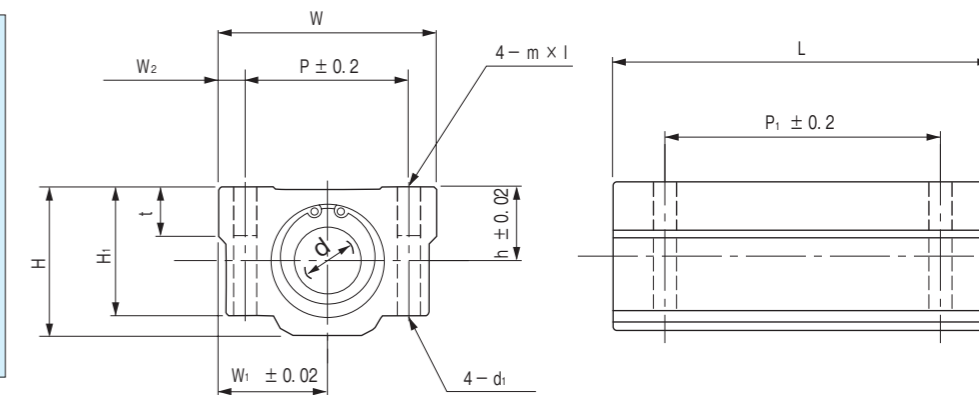

Shaft Diameter (mm)	Code Name	Major Dimensions (mm)													Basic Load Rating	
		d	W	H	L	h	W ₁	H ₁	W ₂	t	P	P ₁	m×l	d ₁	C (N)	C ₀ (N)
6	TBCW-6UU	6	30	18	48	9	15	15	5	6	20	36	M 4×8	3.4	323	529
8	TBCW-8UU	8	34	22	58	11	17	18	5	7	24	42	M 4×8	3.4	431	784
10	TBCW-10UU	10	40	26	68	13	20	21	6	8	28	46	M 5×10	4.3	588	1097
12	TBCW-12UU	12	42	29	70	15	21	25	5.75	8	30.5	50	M 5×10	4.3	656	1,195
13	TBCW-13UU	13	44	30	75	15	22	26	5.5	10	33	50	M 5×10	4.3	813	1,568
16	TBCW-16UU	16	50	38.5	85	19	25	32.5	7	12	36	60	M 5×10	4.3	1,225	2,352
20	TBCW-20UU	20	54	42	96	21	27	36	7	13	40	70	M 6×12	5.2	1,401	2,744
25	TBCW-25UU	25	76	51.5	130	26	38	42	11	15	54	100	M 8×18	7	1,558	3,136
30	TBCW-30UU	30	78	59.5	140	30	39	49	10	18	58	110	M 8×18	7	2,489	5,488
35	TBCW-35UU	35	90	68	155	34	45	54	10	20	70	120	M 8×18	7	2,646	6,272
40	TBCW-40UU	40	102	78	175	40	51	62	11	23	80	140	M10×25	8.7	3,430	8,036

● Code Name

