

■ Housing Unit type TBH series

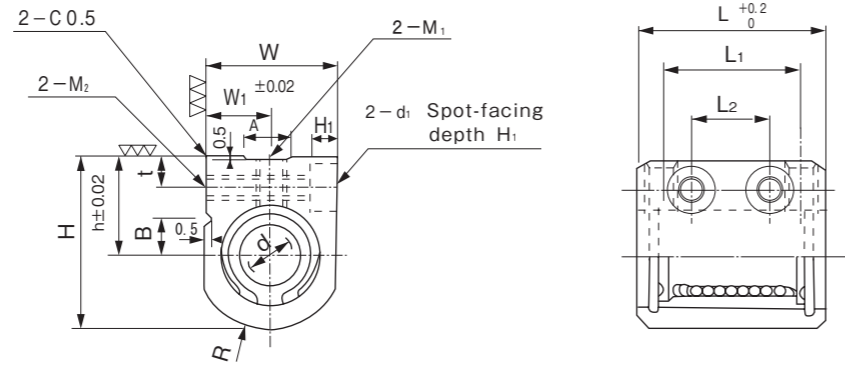

■ Housing Unit Double type TBHW series

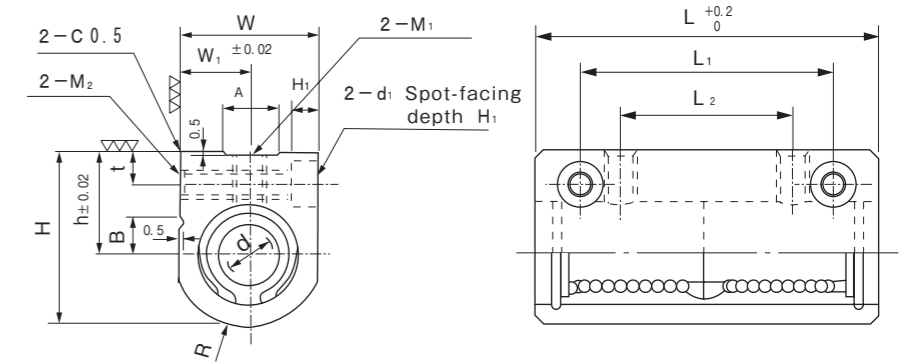

Shaft Diameter (mm)	Code Name	Major Dimensions (mm)															Basic Load Rating	
		d	L	L ₁	L ₂	H	h	t	R	W	W ₁	A	B	M ₁	M ₂	d ₁ × H ₁	C (N)	C ₀ (N)
6	TBH-6UU	6	27	18	9	22	14	5	12	16	8	5	4	4	4	6 × 5	205	264
8	TBH-8UU	8	32	20	10	26	16	5	15	20	10	7	6	5	4	6 × 5	264	401
10	TBH-10UU	10	39	27	15	32	19	6	18	26	13	8	7	6	5	8 × 6	372	548
12	TBH-12UU	12	40	27	15	34	20	6	20	28	14	9	7	6	5	8 × 6	411	597
13	TBH-13UU	13	42	28	16	43	25	7	21.5	30	15	9	8	6	6	9 × 7	509	774
16	TBH-16UU	16	47	32	18	49	27	7	26.5	36	18	11	8	6	6	9 × 7	774	1,176
20	TBH-20UU	20	52	36	18	54	31	8	28	42	21	13	10	8	8	11 × 8	862	1,372
25	TBH-25UU	25	69	42	22	65	37	9	34	52	26	17	15	10	10	14 × 10	980	1,568
30	TBH-30UU	30	74	44	22	71	40	9	37	58	29	19	15	10	10	14 × 10	1,568	2,744

Shaft Diameter (mm)	Code Name	Major Dimensions (mm)															Basic Load Rating	
		d	L	L ₁	L ₂	H	h	t	R	W	W ₁	A	B	M ₁	M ₂	d ₁ × H ₁	C (N)	C ₀ (N)
6	TBHW-6UU	6	46	30	20	22	14	5	12	16	8	5	4	4	4	6 × 5	323	529
8	TBHW-8UU	8	56	42	30	26	16	5	15	20	10	7	6	5	4	6 × 5	431	784
10	TBHW-10UU	10	68	50	36	32	19	6	18	26	13	8	7	6	5	8 × 6	588	1,097
12	TBHW-12UU	12	70	50	36	34	20	6	20	28	14	9	7	6	5	8 × 6	656	1,195
13	TBHW-13UU	13	74	55	42	43	25	7	21.5	30	15	9	8	6	6	9 × 7	813	1,568
16	TBHW-16UU	16	84	65	52	49	27	7	26.5	36	18	11	8	6	6	9 × 7	1,225	2,352
20	TBHW-20UU	20	94	70	58	54	31	8	28	42	21	13	10	8	8	11 × 8	1,401	2,744
25	TBHW-25UU	25	128	100	80	65	37	9	34	52	26	17	15	10	10	14 × 10	1,558	3,136
30	TBHW-30UU	30	138	110	90	71	40	9	37	58	29	19	15	10	10	14 × 10	2,489	5,488

● Code Name

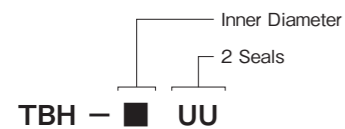

● Code Name

