

Compact Flange (Spigot-joint) type CFTBI series

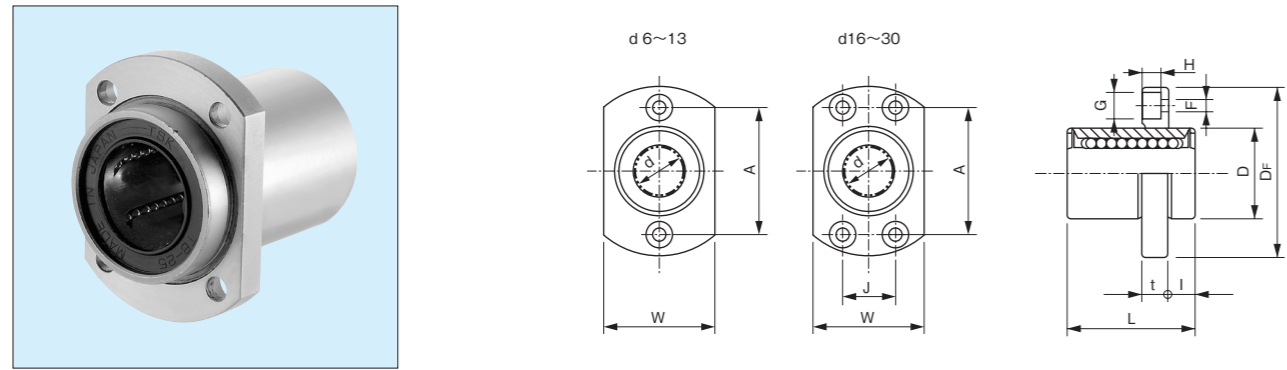

Shaft Diameter (mm)	Code Name	Major Dimensions (mm)												Perpendicularity (μm)	Eccentricity (MAX) (μm)	Basic Load Rating	
		d	D	L	D _F	t	J	W	A	F	G	H	I			C (N)	C ₀ (N)
6	CFTBI-6UU	6	12	19	28	5	-	18	20	3.5	6	3.1	5	12	12	205	264
8	CFTBI-8UU	8	15	24	32	5	-	21	24	3.5	6	3.1	5			264	401
10	CFTBI-10UU	10	19	29	40	6	-	25	29	4.5	7.5	4.1	6			372	548
12	CFTBI-12UU	12	21	30	42	6	-	27	32	4.5	7.5	4.1	6			411	597
13	CFTBI-13UU	13	23	32	43	6	-	29	33	4.5	7.5	4.1	6			509	774
16	CFTBI-16UU	16	28	37	48	6	22	34	31	4.5	7.5	4.1	6			774	1,176
20	CFTBI-20UU	20	32	42	54	8	24	38	36	5.5	9	5.1	8	15	15	862	1,372
25	CFTBI-25UU	25	40	59	62	8	32	46	40	5.5	9	5.1	8			980	1,568
30	CFTBI-30UU	30	45	64	74	10	35	51	49	6.6	11	6.1	10			1,568	2,744

Compact Flange (Spigot-joint) Double type CFTBIW series

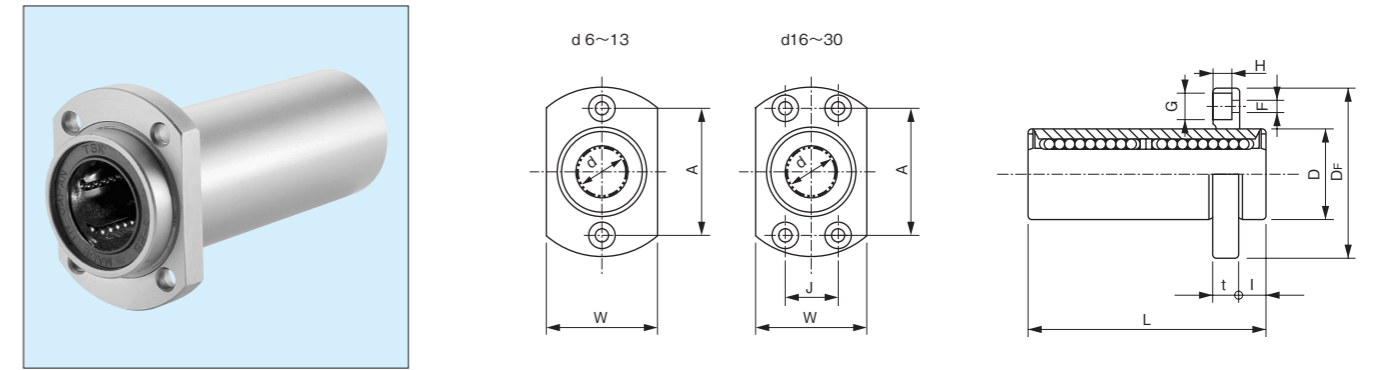

Shaft Diameter (mm)	Code Name	Major Dimensions (mm)												Perpendicularity (μm)	Eccentricity (MAX) (μm)	Basic Load Rating	
		d	D	L	D _F	t	J	W	A	F	G	H	I			C (N)	C ₀ (N)
6	CFTBIW-6UU	6	12	35	28	5	-	18	20	3.5	6	3.1	5	15	15	323	529
8	CFTBIW-8UU	8	15	45	32	5	-	21	24	3.5	6	3.1	5			431	784
10	CFTBIW-10UU	10	19	55	40	6	-	25	29	4.5	7.5	4.1	6			588	1,097
12	CFTBIW-12UU	12	21	57	42	6	-	27	32	4.5	7.5	4.1	6			656	1,195
13	CFTBIW-13UU	13	23	61	43	6	-	29	33	4.5	7.5	4.1	6			813	1,568
16	CFTBIW-16UU	16	28	70	48	6	22	34	31	4.5	7.5	4.1	6			1,225	2,352
20	CFTBIW-20UU	20	32	80	54	8	24	38	36	5.5	9	5.1	8	20	20	1,401	2,744
25	CFTBIW-25UU	25	40	112	62	8	32	46	40	5.5	9	5.1	8			1,558	3,136
30	CFTBIW-30UU	30	45	123	74	10	35	51	49	6.6	11	6.1	10			2,489	5,488

Code Name

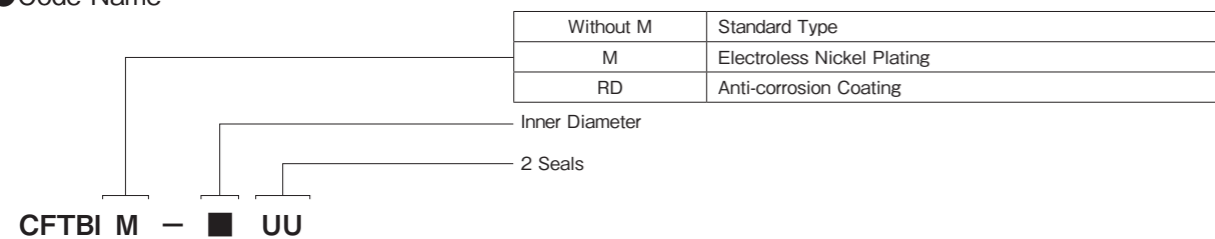

Code Name

