

Standard Long Type SBSL Series

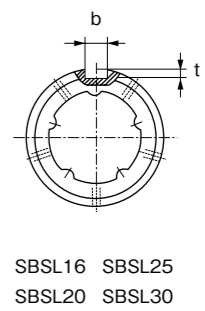
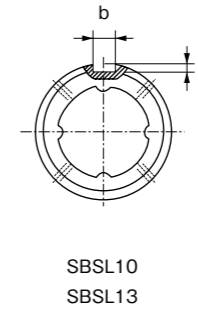
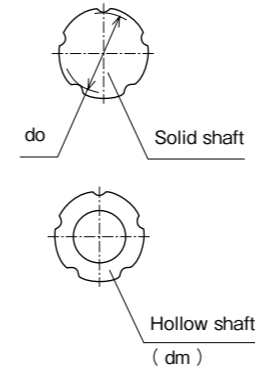
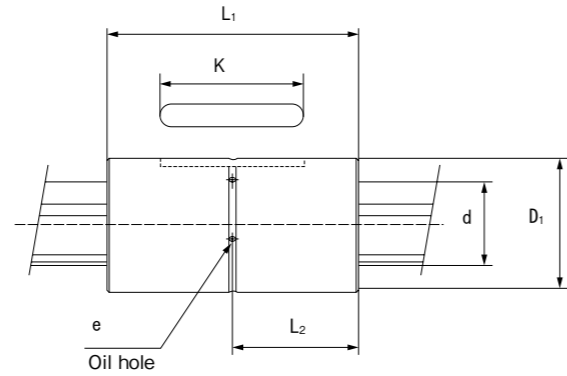
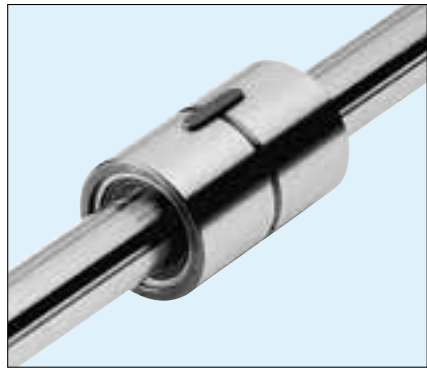

Shaft dia. (mm)	Model #		Outer dia.		Length L ₁	Dimensions of keyway					L ₂	Oil hole e	Bore dia. dm
	No seal	With seals	D ₁	(h6)		b	(H8)	t	(Tol.)	K			
10	SBSL10	SBSL10UU	21	0	40	3	+0.014	1.5	+0.050 0	17	20	1.5	4
13	SBSL13	SBSL13UU	24	-0.013	44	3	0	1.5		17	22	1.5	4
16	SBSL16	SBSL16UU	31	0	50	3.5	+0.018 0	2	+0.050 0	18	25	1.5	6
20	SBSL20	SBSL20UU	35		63	4		2.5		29	31.5	2	8
25	SBSL25	SBSL25UU	42		71	4		2.5		33	35.5	2	12
30	SBSL30	SBSL30UU	47		80	4		2.5		42	40	2.5	17

Minor dia. do	Number of grooves	Basic rated radial load (kN)		Basic rated torque (N · m)		Static rated moment (N · m)		Weight (kg)		Dia. (h7) d
		Dynamic Cr	Static Cor	Dynamic Ct	Static Cot	Mpo- I	Mpo- II	Shaft/m	Sleeve	
10	4	3.8	6.9	19	34	26	181	0.65	0.06	10.4
13		4.6	8.3	28	52	36	251	1.11	0.07	13.4
16	5	6.2	11.1	51	93	56	386	1.65	0.15	16.6
20		8.5	15.3	85	154	83	611	2.57	0.2	20.6
25		15.4	27.7	193	348	173	1248	4.04	0.29	25.8
30		18.5	33.3	272	490	212	1581	5.85	0.37	30.8

Code Name

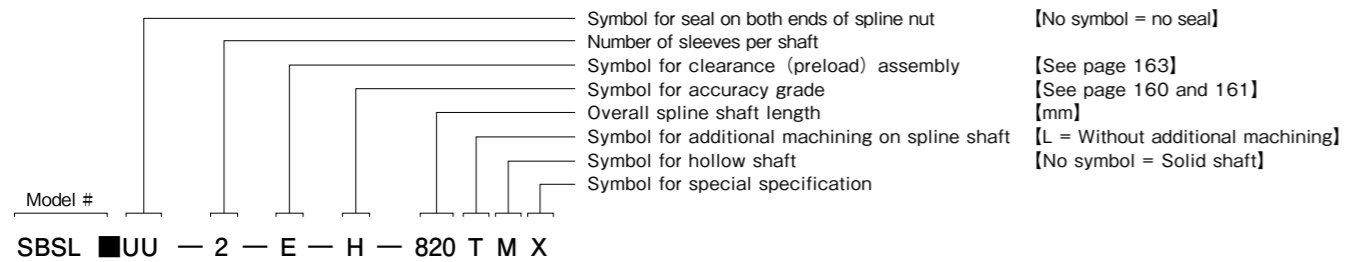

- Note
- 1) Spline nut and shaft are supplied as a matched set.
 - 2) See page 164 for fitting dimensions between spline nut and housing box.
 - 3) See page 164 for detailed dimensions of keyway and key.