

TSK High Speed Rolled Ball Screw RBH series

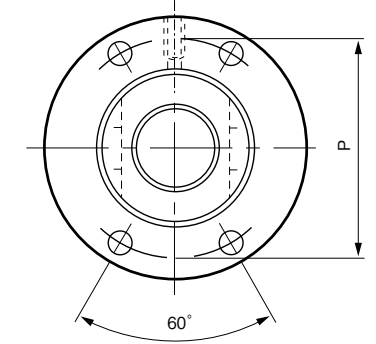
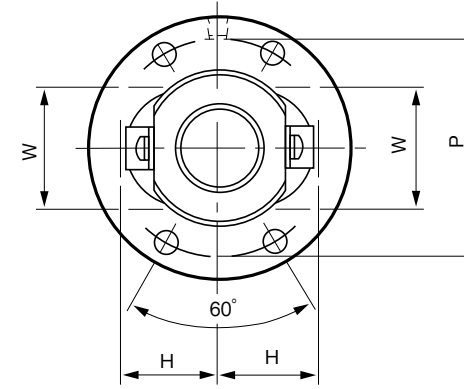
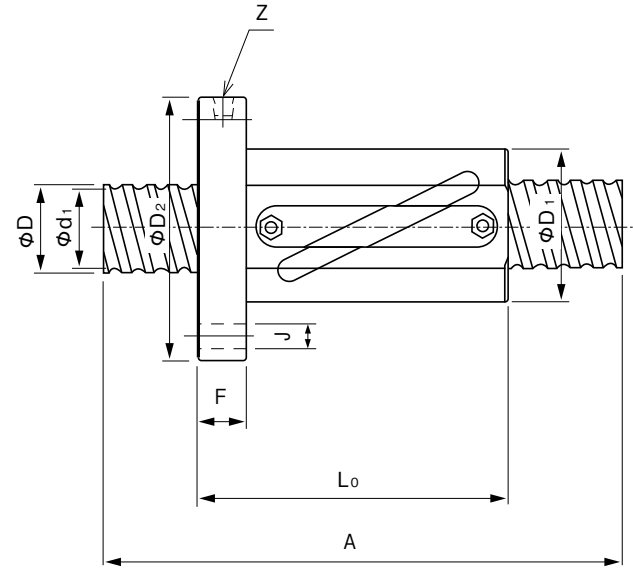

RBH1510

Unit : mm

Identification Number	Screw Shaft		Lead l	Circuit Direction	Ball Circle Diameter d	Number of Circuits m	Nut		Flange			
	Outer Dia. D	Root Dia. d_1					O.D. D_1	Length L_0	O.D. D_2	Thickness F	P.C.D. P	Hole Dia. J
RBH 1212	12	10.1	12 (6)	Right	2.381	3	25	44	44	10	34	4.5
RBH 1510	15	12.2	10 (5)	Right	3.178	5	34	51	57	10	45	5.5
RBH 1616	16	13.7	16 (8)	Right	2.778	3	30	57	57	10	44	5.5
RBH 2020	20	17.5	20 (10)	Right	3.175	3	34	67	60	10	47	5.5
RBH 2525	25	21.9	25 (12.5)	Right	3.969	3	44	81	71	12	57	6.6
RBH 3232	32	28.4	32 (16)	Right	4.763	3	56	98	90	15	72	9
RBH 3636	36	31.8	36 (18)	Right	5.556	3	60	110	100	18	80	11
RBH 4040	40	35.2	40 (20)	Right	6.35	3	65	123	107	18	85	11

Return Tube		Oil Hole Z	Axial Play	Basic Load Rating (N)		Shaft Length (MAX) A	Identification Number
Width W	Height H			Dynamic C_a	Static C_{oa}		
16	17	M6×0.75	0.10	3300	5200	1000	RBH 1212
—	—	M6×0.75	0.10	8300	13500	1500	RBH 1510
23	23	M6×0.75	0.10	4600	8000	1500	RBH 1616
26	23	M6×0.75	0.10	6200	11600	2000	RBH 2020
34	30	M6×0.75	0.12	9300	18100	2500	RBH 2525
41	34	M6×0.75	0.14	13200	27500	3500	RBH 3232
45	38	PT1/8	0.17	17500	37300	3500	RBH 3636
51	41	M6×0.75	0.19	21700	46400	4000	RBH 4040

Note : 1.The basic load rating (C_o, C_{oa}) values are based on a rated life standard of 250km or 10^6 revolutions.
2.Wipers can be also installed.

Code Name

