

TSK Cross Roller Slide TCR1

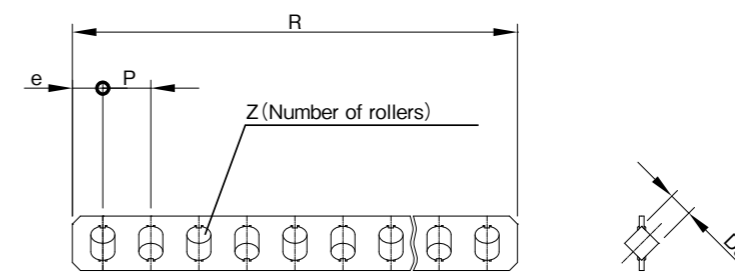
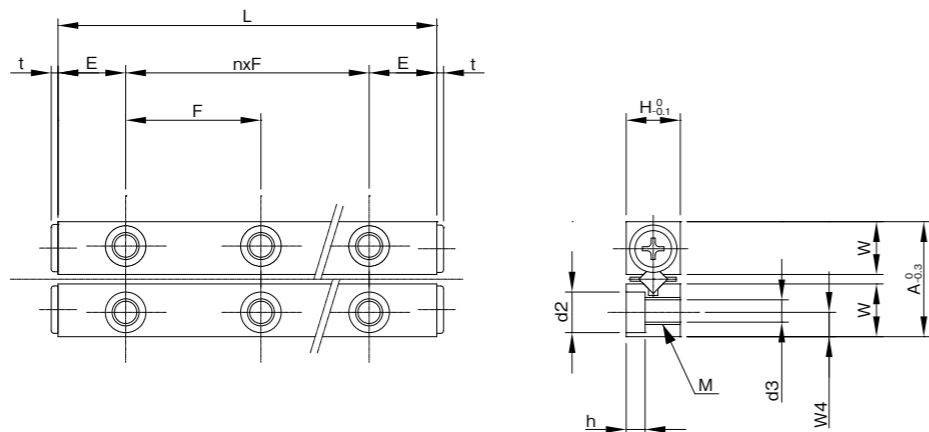

Model #	Stroke (mm)	No. of rollers (pcs.)	Main							
			A	H	L	nxF	E	Da	R	P
TCR1020- 5Z	13	5	8.5	4	20	1×10	5	1.5	15.8	3
TCR1030- 7Z	21	7			30	2×10			21.8	
TCR1040- 9Z	29	9			40	3×10			27.8	
TCR1050-11Z	37	11			50	4×10			33.8	
TCR1060-13Z	45	13			60	5×10			39.8	
TCR1070-15Z	53	15			70	6×10			45.8	
TCR1080-17Z	61	17			80	7×10			51.8	

dimensions (mm)								Basic load rating (N) *		Model #
e	W	W4	M	d3	d2	h	t	Dynamic C	Static Co	
1.9	3.9	1.8	M2	1.65	3	1.4	0.5	125	144	TCR1020- 5Z TCR1030- 7Z TCR1040- 9Z TCR1050-11Z TCR1060-13Z TCR1070-15Z TCR1080-17Z

\* Note : The load capacity per needs roller.

Code Name

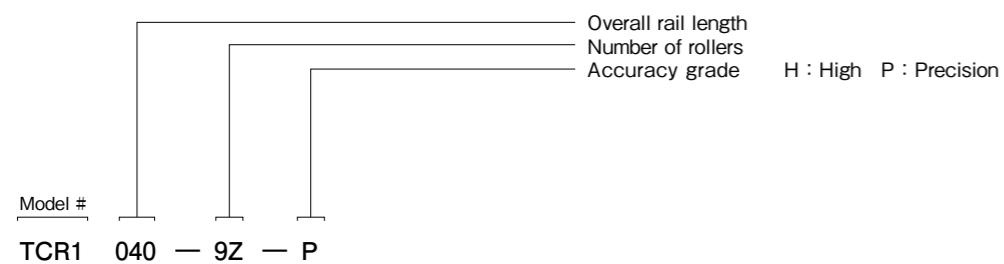

TSK Cross Roller Slide TCR2

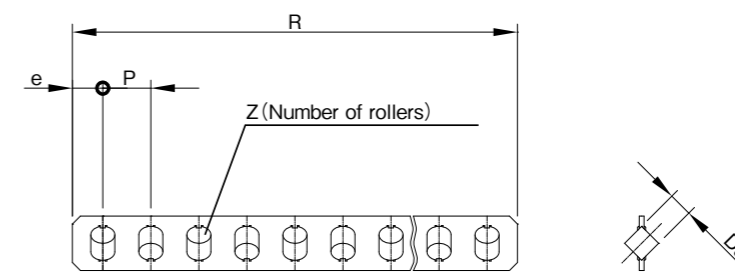
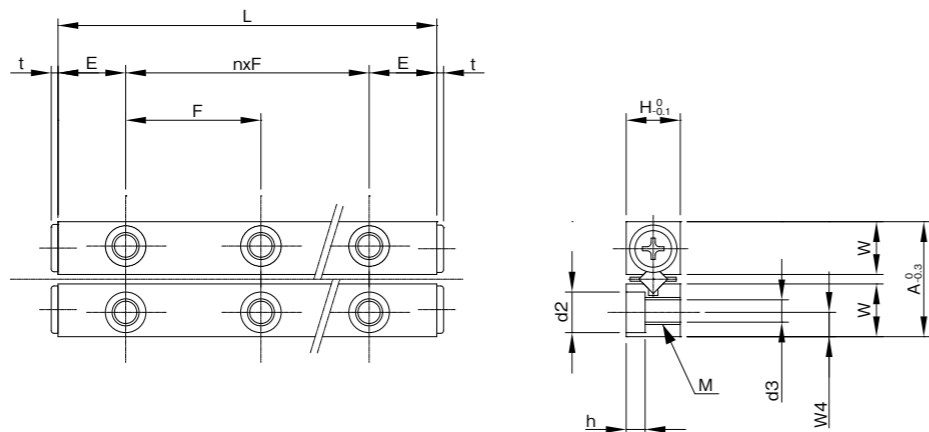

Model #	Stroke (mm)	No. of rollers (pcs.)	Main								
			ST	Z	A	H	L	nxF	E	Da	R
TCR2030- 5Z	24	5	12	6	30	1 × 15	7.5	2	21.6	4	
TCR2045- 8Z	30	8			45	2 × 15					33.6
TCR2060-10Z	44	10			60	3 × 15					41.6
TCR2075-12Z	58	12			75	4 × 15					49.6
TCR2090-14Z	72	14			90	5 × 15					57.6
TCR2105-16Z	86	16			105	6 × 15					65.6
TCR2120-18Z	100	18			120	7 × 15					73.6
TCR2135-21Z	106	21			135	8 × 15					85.6
TCR2150-23Z	120	23			150	9 × 15					93.6
TCR2165-25Z	134	25			165	10 × 15					101.6
TCR2180-27Z	148	27			180	11 × 15					109.6

dimensions (mm)								Basic load rating (N) *		Model #
e	W	W4	M	d3	d2	h	t	Dynamic C	Static Co	
2.8	5.5	2.5	M3	2.55	4.4	2	0.8	293	292	TCR2030- 5Z
										TCR2045- 8Z
										TCR2060-10Z
										TCR2075-12Z
										TCR2090-14Z
										TCR2105-16Z
										TCR2120-18Z
										TCR2135-21Z
										TCR2150-23Z
										TCR2165-25Z
										TCR2180-27Z

\* Note : The load capacity per needs roller.

Code Name

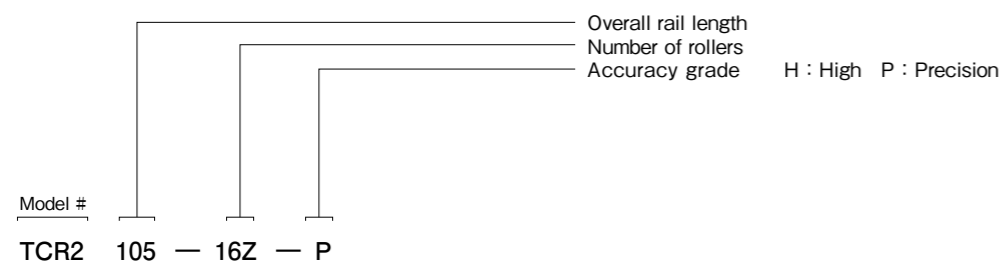

TSK Cross Roller Slide TCR3

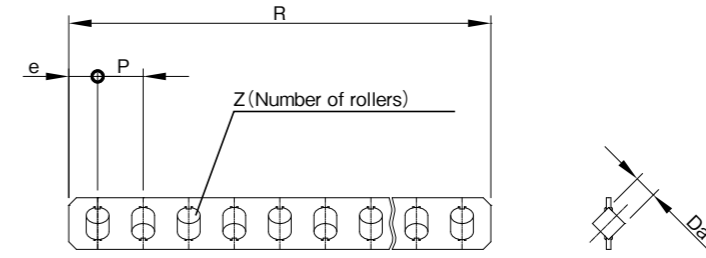
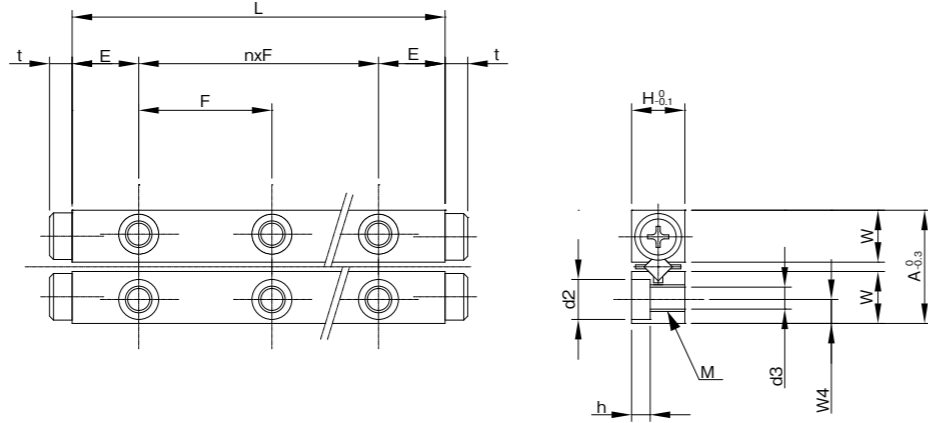
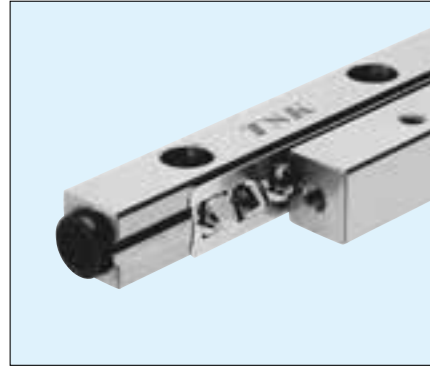

Model #	Stroke (mm)	No. of rollers (pcs.)	Main								
			A	H	L	nxF	E	Da	R	P	
TCR3050-7Z	34	7	18	8	50	1×25	12.5	3	36.4	5	
TCR3075-10Z	54	10			75	2×25					51.4
TCR3100-13Z	74	13			100	3×25					66.4
TCR3125-15Z	104	15			125	4×25					76.4
TCR3150-18Z	124	18			150	5×25					91.4
TCR3175-21Z	144	21			175	6×25					106.4
TCR3200-24Z	164	24			200	7×25					121.4
TCR3225-27Z	184	27			225	8×25					136.4
TCR3250-30Z	204	30			250	9×25					151.4
TCR3275-33Z	224	33			275	10×25					166.4
TCR3300-36Z	244	36			300	11×25					181.4

dimensions (mm)								Basic load rating (N) *		Model #
e	W	W4	M	d3	d2	h	t	Dynamic C	Static Co	
3.2	8.3	3.5	M4	3.3	6	3.1	2	638	761	TCR3050-7Z TCR3075-10Z TCR3100-13Z TCR3125-15Z TCR3150-18Z TCR3175-21Z TCR3200-24Z TCR3225-27Z TCR3250-30Z TCR3275-33Z TCR3300-36Z

\* Note : The load capacity per needs roller.

Code Name

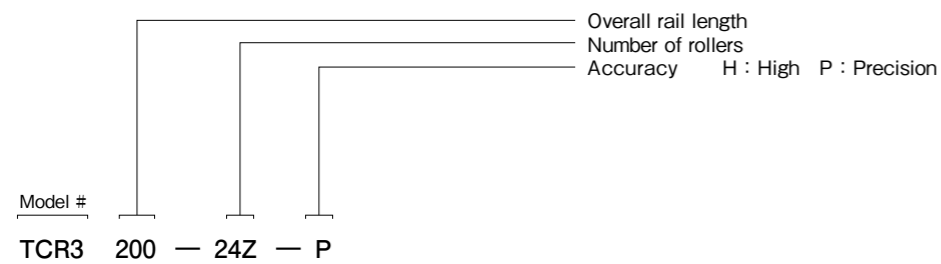

TSK Cross Roller Slide TCR4

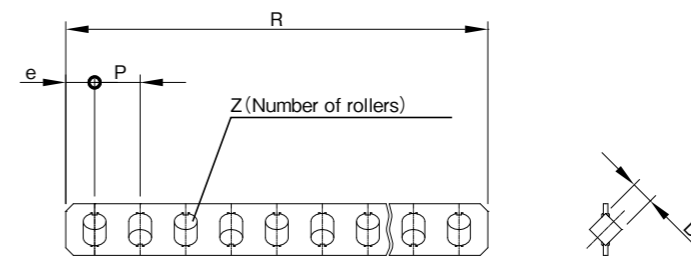
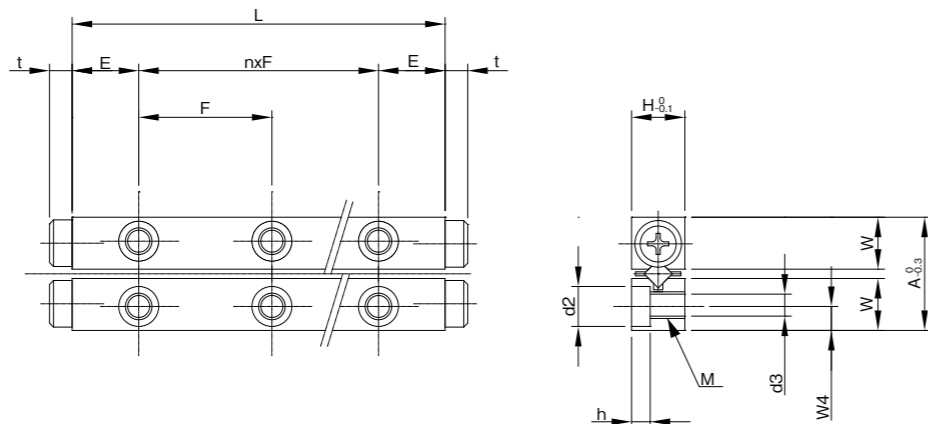

Model #	Stroke (mm)	No. of rollers (pcs.)	Main								
			A	H	L	nxF	E	Da	R	P	
TCR4080-8Z	54	8	22	11	80	1×40	20	4	57.6	7	
TCR4120-11Z	92	11			120	2×40					78.6
TCR4160-14Z	130	14			160	3×40					99.6
TCR4200-18Z	154	18			200	4×40					127.6
TCR4240-21Z	192	21			240	5×40					148.6
TCR4280-24Z	230	24			280	6×40					169.6
TCR4320-28Z	254	28			320	7×40					197.6
TCR4360-31Z	292	31			360	8×40					218.6
TCR4400-34Z	330	34			400	9×40					239.6
TCR4440-38Z	354	38			440	10×40					267.6
TCR4480-41Z	392	41			480	11×40					288.6

dimensions (mm)								Basic load rating (N) *		Model #
e	W	W4	M	d3	d2	h	t	Dynamic C	Static Co	
4.3	10	4.5	M5	4.3	7.5	4.1	1	1,230	1,170	TCR4080-8Z
										TCR4120-11Z
										TCR4160-14Z
										TCR4200-18Z
										TCR4240-21Z
										TCR4280-24Z
										TCR4320-28Z
										TCR4360-31Z
										TCR4400-34Z
										TCR4440-38Z
										TCR4480-41Z

\* Note : The load capacity per needs roller.

Code Name

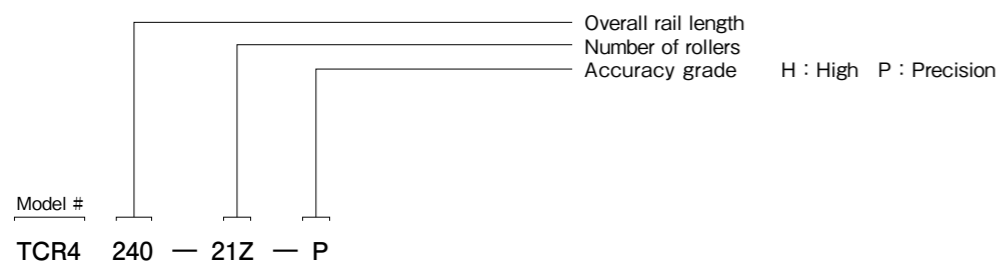

TSK Cross Roller Slide TCR6

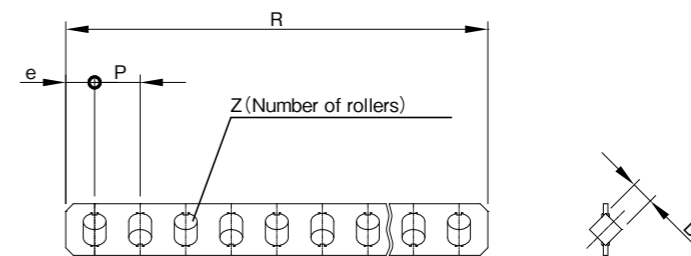
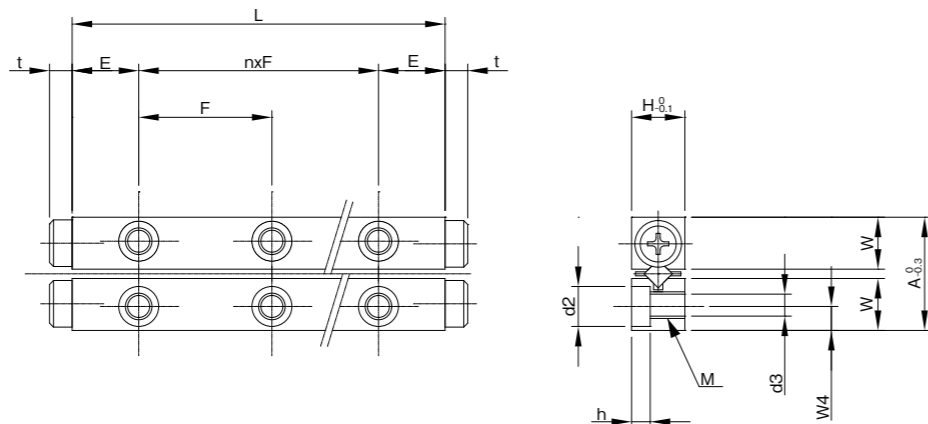

Model #	Stroke (mm)	No. of rollers (pcs.)	Main							
			A	H	L	nxF	E	Da	R	P
TCR6100-7Z	80	7	31	15	100	1×50	25	6	64.8	9
TCR6150-11Z	108	11			150	2×50			100.8	
TCR6200-14Z	154	14			200	3×50			127.8	
TCR6250-17Z	200	17			250	4×50			154.8	
TCR6300-20Z	246	20			300	5×50			181.8	
TCR6350-24Z	274	24			350	6×50			217.8	
TCR6400-27Z	320	27			400	7×50			244.8	
TCR6450-30Z	366	30			450	8×50			271.8	
TCR6500-33Z	412	33			500	9×50			298.8	
TCR6550-36Z	458	36			550	10×50			325.8	
TCR6600-40Z	486	40			600	11×50			361.8	

dimensions (mm)								Basic load rating (N) *		Model #
e	W	W4	M	d3	d2	h	t	Dynamic C	Static Co	
5.4	14	6	M6	5.3	9.5	5.2	3	2,570	2,632	TCR6100-7Z
										TCR6150-11Z
										TCR6200-14Z
										TCR6250-17Z
										TCR6300-20Z
										TCR6350-24Z
										TCR6400-27Z
										TCR6450-30Z
										TCR6500-33Z
										TCR6550-36Z
										TCR6600-40Z

\* Note : The load capacity per needs roller.

Code Name

